



About the Collaboration Prize

The Collaboration Prize is designed to inspire cooperation among nonprofit organizations. Recognizing the efficiencies gained from working together, the Prize shines a spotlight on collaborations among two or more nonprofit organizations that each would otherwise provide the same or similar programs or services and compete for clients, financial resources, or staff.

In the summer of 2008, over 600 nominations were received for the inaugural year of the Prize. Each nomination was evaluated according to a comprehensive scoring rubric. The collaborations that advanced demonstrated through quantifiable evidence that they achieved exceptional impact and substantially eliminated the duplication of efforts through programmatic collaborations, administrative consolidation, or other joint activities.

The Collaboration Prize was created by the Lodestar Foundation. Lodestar seeks to identify achievements in collaboration as models for inspiration and replication in the nonprofit world. The Prize also seeks to build an information base of effective practice models that can be studied and used by academics, nonprofit leaders, and grantmakers to inspire and advance their work. True to the spirit of collaboration, the Lodestar Foundation has partnered with the AIM Alliance on these efforts.

The Arizona-Indiana-Michigan (AIM) Alliance is a collaboration comprised of The Lodestar Center for Philanthropy and Nonprofit Innovation at Arizona State University, The Center on Philanthropy at Indiana University, and The Johnson Center for Philanthropy and Nonprofit Leadership at Grand Valley State University (Michigan). The AIM Alliance assists in promoting and publicizing the Collaboration Prize, reviewing nominations, and selecting semi-finalists. The AIM Alliance is also involved in creating articles, white papers, and research to inform and inspire others in the sector.

Acknowledgements

Models of Collaboration is a publication of the ASU Lodestar Center, an academic center that seeks to advance nonprofit leadership practice. The brief was authored by Mark A. Hager and Tyler Curry. The project received invaluable support from Robert F. Ashcraft, Jill Watts, Amy O'Hara, and Felipe Ruiz (layout and design).

Copyright © 2009 Arizona Board of Regents for and on behalf of the ASU Lodestar Center for Philanthropy and Nonprofit Innovation, College of Public Programs, Arizona State University. All rights reserved. No part of this publication may be reproduced, stored in a retrieval system, or transmitted in any form or by any means, electronic, mechanical, photocopying, recording, or otherwise without the express written permission of the ASU Lodestar Center, except for brief quotations in critical reviews. The authors may be reached at the ASU Lodestar Center, 411 N. Central Ave., Suite 500, Phoenix, AZ 85004-0691.

Model 1: Fully-Integrated Merger

The most common type of collaboration among the 2009 Collaboration Prize quarterfinalists is the fully-integrated merger. As the name implies, this collaboration occurs when two or more organizations combine their operations and missions into a single organization.

The merger is usually achieved when one organization merges with another, thereby preserving the corporate status and charitable exemption of one of the partners. However, sometimes the two partners choose to incorporate as a totally new, merged organization.

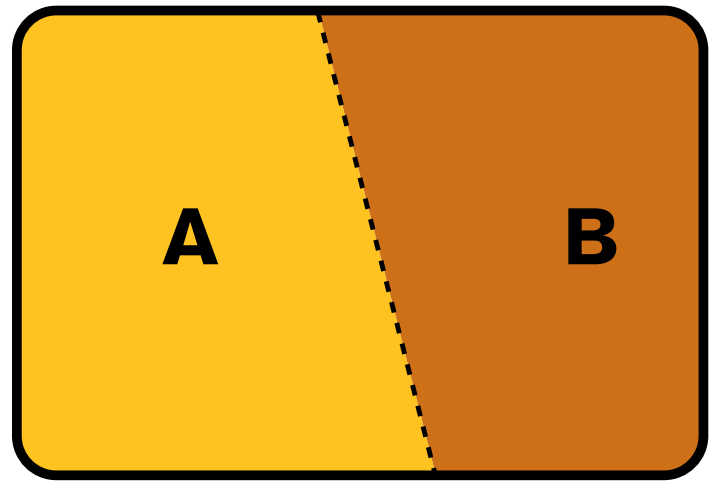

conditions

- Collaborators need to have similar or complementary missions.
- An overlap in services provides the basis for efficiencies.
- Competition for funding and clients.
- Pressure from the community to address duplication of service.

challenges

- Overcoming the spirit of competition and replacing it with cooperation.
- Integrating organizations with different histories and cultures.
- Determining a new leadership structure without duplicating positions.
- Establishing a new board structure and leadership

benefits

- Increased efficiency in delivery of programs.
- Elimination of overlapping services at the community level.
- Greater economy of scale can lead to greater access to resources.
- Adopting the strengths of each collaborator can create a much stronger whole.

A fully-integrated merger: Marywood Palm Valley School

For many years, Rancho Mirage, California, supported two private schools geared toward preparing students for college: Palm Valley School and Marywood Country Day School. However, both fell below capacity amid a perception that “only the local public schools could offer a more complete social experience.”

Although the schools had their own unique cultures and history, the boards realized that they could offer more programs if they doubled their size through a merger. In order to retain certification, tax-exempt status, and worker compensation funds, Marywood Country Day School was absorbed by Palm Valley School, creating Marywood Palm Valley, a merger of equals.

The two headmasters became head and associate head of the new school. The two board chairs became chair and vice-chair of the new school. The greatest challenge was in convincing the parents, many of whom had emotional investments in their chosen schools. “Despite the sometimes-intense emotional reaction by parents or even board members, it was the unwavering leadership by the Head that soothed emotions and carried the school over the many small bumps along the way.”

Model 2: Partially-Integrated Merger

An alternative to a full merger is a combination of organizations that does not result in the total loss of brand for the two collaborators: a partially-integrated merger.

Two or more nonprofits might be formally merged in a partially-integrated case, but the individual characters of the merged organizations are maintained in some way. Rather than being a “merger that doesn’t quite take,” the partially-integrated merger model is consciously chosen to pursue strategic advantages inherent in each of the collaborators. Some individuality is maintained.

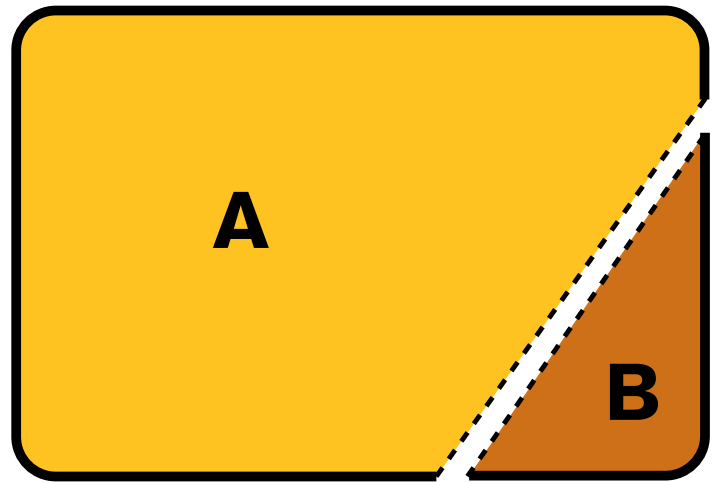

conditions

- Typically a stronger or larger organization extends support to a less developed or smaller one.
- Overlap in customer base and services, with resulting competition for funding.
- Clear strategic advantage from retaining the name or branded programs of the smaller partner.

challenges

- Clients and other stakeholders may see the collaboration as a takeover rather than a partnership.
- The stronger partner may need to weigh risks of supporting the capacity needs of the other partner.
- The identity of the less developed partner can be overshadowed by a more dominant organization.

benefits

- Gains in resources, stability, and capacity for the less developed partner.
- The dominant partner gains the benefits of established programs that it may not have developed easily on its own.
- Elimination of competition and overlapping services.

Partial Integration: Public Health Management Corporation and La Comunidad Hispana

For over 30 years, La Comunidad Hispana served the health, educational, and social service needs of low-income Hispanics in Chester County, Pennsylvania. However, like many similar nonprofits, it operated on a budget that did not match its aspirations, so it constantly faced challenges in funding, capacity, and management.

As Philadelphia's Public Health Management Corporation grew, it sought to expand its services to neighboring counties, including Chester County. Despite its strong infrastructure and sound financial base, it lacked the history and name recognition necessary to gain the trust of Chester County's Hispanic families.

So, an agreement was struck between the two organizations. La Comunidad Hispana became an affiliate of Public Health Management Corporation, a subsidiary where Public Health Management Corporation is the sole member of La Comunidad Hispana, and La Comunidad Hispana partakes of fiscal services, human resources, information systems, program development, marketing, communications, and other services provided by Public Health Management Corporation. La Comunidad Hispana maintains its corporate identity, but now serves its constituents from a stronger base.

Model 3: Joint Program Office

Imagine two complementary organizations that separately maintain their various program offices. A merger may not fit their needs, but an overlap in some programs or services may provide the opportunity for collaboration.

A joint program office requires no new programs or organizational structures. Rather, two or more organizations combine on one or more programs for the purpose of strengthening the efforts of both organizations.

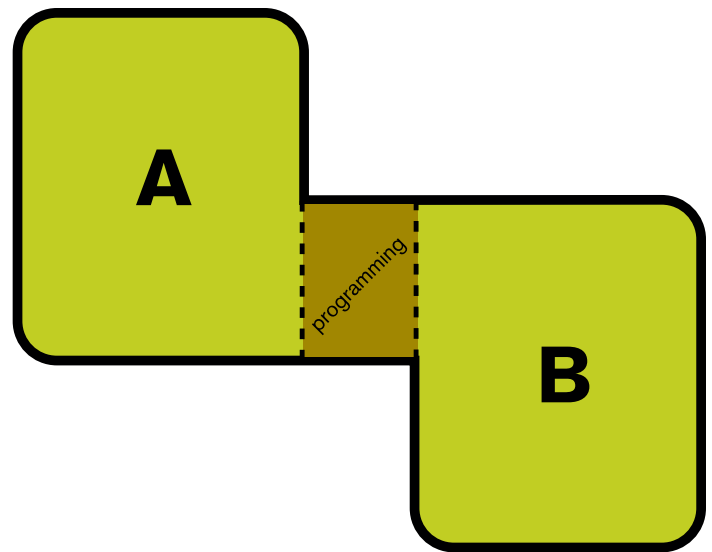

conditions

- Similar, but not exactly the same, programs and services offered to the same audience.
- Competition for funding.
- A shared, overall mission.
- Recognizing the benefits of collaboration, but not a substantial integration.

challenges

- Determining an appropriate and fair mix of program staff from each collaborator.
- Clear rules for which organization is responsible for program fundraising, strategic direction, and operating expenses.
- Establishing appropriate lines of communication from the joint office to each collaborator.

benefits

- Synergy from joined forces.
- Economy of scale for select services, resulting in more efficient use of resources.
- Retained sovereignty of collaborators.
- Facilitates communication on shared issues and concerns.

Joint Program Office: The Disability Policy Collaboration

The Arc of the United States serves persons with intellectual disabilities and their families. United Cerebral Palsy oversees a national affiliate network that provides direct services to children and adults with disabilities. Although their constituent bases are different, both have a vested interest in advancing policies that support the interests of people with disabilities.

Like many advocacy organizations in Washington, DC, both maintained government affairs programs, including efforts to cultivate relationships with Members of Congress and federal agencies, and to mobilize grassroots networks that can be called upon for citizen action. The Arc and United Cerebral Palsy recognized the potential of “combining for a more powerful voice for people with disabilities” through a joint government affairs office.

One office serves the needs of both organizations. Six staff members are formally employed by the Arc, and two are employed by United Cerebral Palsy. Nonetheless, they work together and report together to the directors of the two collaborators. Through this arrangement, the advocacy efforts of both organizations are enhanced.

Model 4: Joint Partnership with Affiliated Programming

The development of shared projects by multiple nonprofits is perhaps the most common type of joint partnership. In this case, two or more organizations join their operations for programming or delivery of services.

Several exemplary cases resulted in a coordination of services, so that a continuum of care was clear to both the organizations involved and their clients. In other cases, a program or service is greatly enhanced by the combined efforts of two nonprofits with complementary strengths.

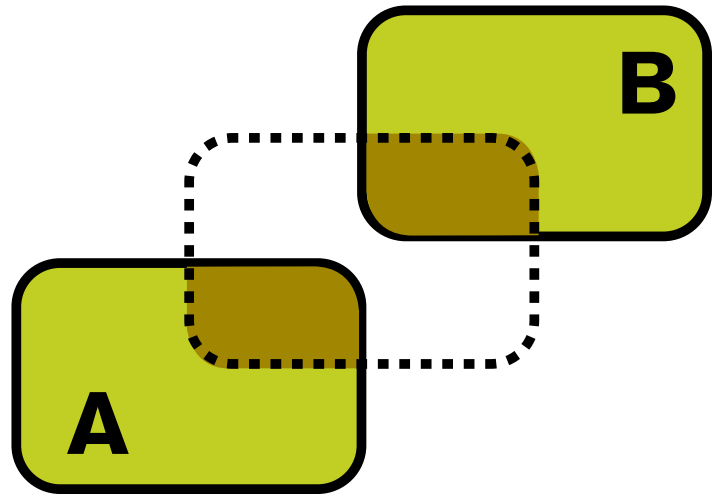

conditions

- Two or more organizations with a shared mission but not necessarily the same services.
- Shared client or audience base.
- Long-term, on-going relationship focused on long-term goals.
- Partially-integrated staff and financial resources.

challenges

- Need for clear delineation of responsibilities when ownership is unclear.
- Determination of which partners can claim credit for outcomes when reporting to their stakeholders.

benefits

- Combined resources allow for greater short- and long-term impact.
- Reduction in fragmentation of services.
- More efficient use of community resources.
- Comprehensive coverage of catchment area.

Joint Partnership, Affiliated Programming: Crayons to Calculators

Many students from Boulder, Colorado's low-income families do not have the school supplies they need when they start school each fall. In fact, the need was so clear that several organizations solicited funds for supplies every year, and new organizations sprang up amid the fragmentation. Impact on Education, Extras for Education, the Sister Carmen Community Center, and Foothills United Way knew there had to be a better way. There was: they founded a joint program called Crayons to Calculators, aimed at developing one program that served all students in need of supplies, without gaps or duplication of effort.

Now, Boulder County social services and area school districts have one organization to go to when they identify students in need. In its third year of operation, Crayons to Calculators provided a backpack filled with school supplies to every student in the Boulder Valley School District who needed help.

One partner serves as the fiduciary agent for Crayons to Calculators, and each partner designates an employee who serves on an oversight committee. Through affiliated programming, both fundraising and service delivery are streamlined and simplified.

Model 5: Joint Partnership for Issue Advocacy

Community organizations occasionally share the need to speak with one voice so that their collective message can be heard amid noise or powerful counter-interests.

A joint partnership model is well-suited for such joint interests, but the short-term or periodic nature of issue advocacy may not require a new, permanent organization. Instead, collaborators lend leadership and staff to joint committees as needed, which allows them to move, communicate, and mobilize in unison.

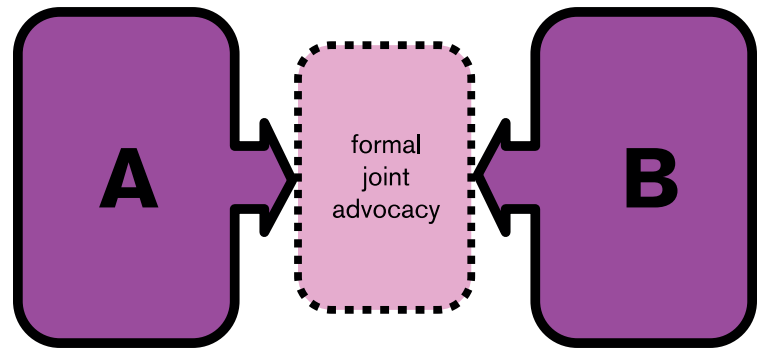

conditions

- Shared long-term missions and short-term goals.
- The need to expand the effort to deal with a particular issue.
- Organizations have different expertise and types of resources.
- Collaborators do not want to compromise their autonomy.

challenges

- Resolving philosophical differences between collaborators to achieve a united front.
- Clear guidelines on which group is responsible for costs and obligations during campaigns.

benefits

- Partnership can mobilize to reach a larger audience.
- Pooled resources allow for greater short-term impact.
- Partnership is more easily assembled and disassembled than in more formal arrangements.
- Coordination of messaging across a field.

Joint Partnership, Issue Advocacy: The California Marriage Equity Partnership

The issue is domestic partnership laws and same-sex marriage rights in California. With strong, organized opposition and the public sharply divided on the issue, the National Center for Lesbian Rights, Lambda Legal, the American Civil Liberties Union, and Equality California recognized the need to present a united front on public education messaging, legislative advocacy, and marriage equality litigation.

The California Marriage Equity Partnership was born as a mechanism for issue advocates to work together. The “Marriage Team” met regularly to assess progress, identify strategic priorities, evaluate successes, and develop new initiatives and messages. Different partners loaned their strengths to the united cause.

The team crystallized at a moment in time when conditions appeared ripe for progress on its chosen issue. By acting together, California became the second state in the country to permit same-sex couples to marry, and the first to welcome out-of-state couples to wed, among other legal and policy victories. The Partnership remains on the forefront amid continuing challenges on the same-sex marriage issue.

Model 6: Joint Partnership with the Birth of a New Formal Organization

Examples of joint partnerships fall within a wide range. One of the more well-known examples is a model where two or more organizations determine that their joint programming is best implemented by forming a separate, independent organization.

The creation of this new organization reflects both a maturity of purpose and a desire for entrepreneurial parent organizations to push a new effort out of the nest and provide the freedom that is sometimes necessary for new social enterprises to flourish.

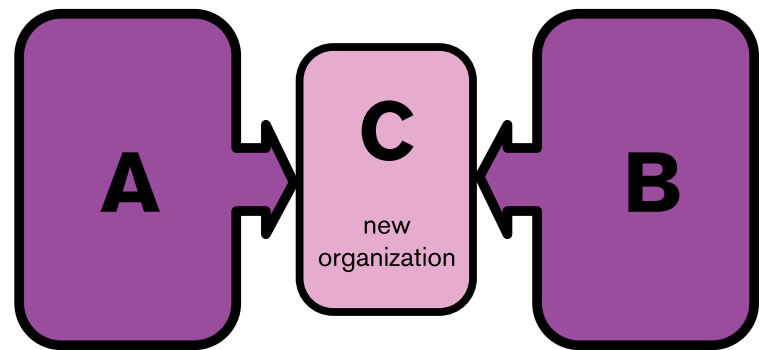

conditions

- Two or more organizations with similar missions and services.
- Competition for funding.
- Recognition of a long-term need that falls outside the current scope of existing organizations.
- Entrepreneurial orientation toward solutions.

challenges

- Willingness to give up ownership to others.
- Generating sustained funding for a new enterprise.
- Perception of the creation of a duplication of services, rather than a streamlining of services.

benefits

- New programming without interrupting the identities or current programming of collaborators.
- Built-in advice and capacity support for the new enterprise.
- Dedicated focus on a new mission that is already validated by community partners.

Joint Partnership, New Formal Organization: CANnect

Across North America, such providers as the Carroll Center for the Blind, the Washington State School for the Blind, the Perkins School for the Blind, and the Canadian National Institute for the Blind serve and advocate for the special needs of the sight-impaired. New media drive these organizations to seek new ways to connect the blind to the burgeoning world of information, but the Internet provides special challenges. Each organization recognized the need to develop the means to help blind individuals use the training, educational, and workplace advantages of the Web.

Rather than compete in the search for and implementation of innovations, these organizations instead founded CANnect, a new, separate organization with a mission of leading the development of a consistent user interface designed according to universal design concepts that cater to the special needs of the blind. CANnect provides the promise of online learning for the sight-impaired.

In this case, the creation of a new entity made the most sense. "Creating a separate organization assured that everyone had ownership." Each of the partner organizations has a seat on the board. "Secondarily, having a distinct organization provides the benefit of a dedicated focus on the mission."

Model 7: Joint Administrative Office and Back Office Operations

In model 3, collaborating nonprofits streamlined some aspect of their program through a joint program office. In a joint administrative office, similar efficiencies are achieved through shared administrative office and personnel, including financial and human resources management, and information technology.

Another approach is to contract administrative functions to a separate organization whose sole job is to provide “back office” support for other organizations.

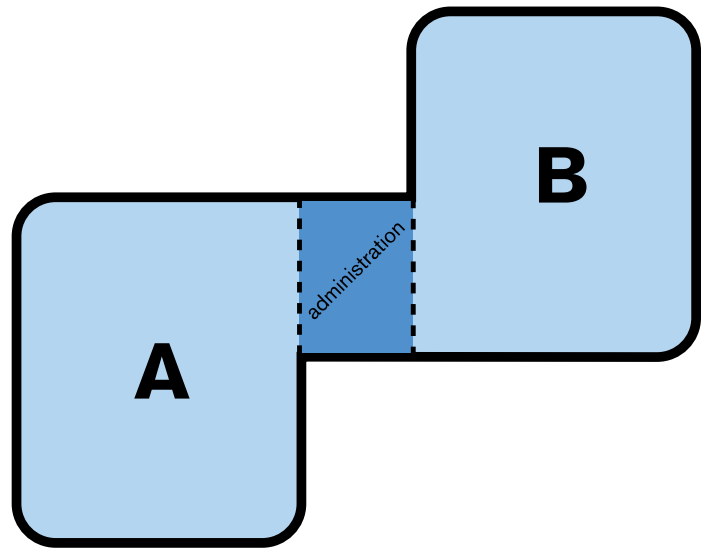

conditions

- Desire to enhance administrative operations.
- Willingness to cope with fuzzy organizational boundaries.
- Desire for partners to maintain sovereignty despite shared organizational tasks.
- Presence of at least one partner with strong administrative processes.

challenges

- The strong partner may dictate administrative processes that collaborators may not have chosen themselves.
- Growth and change may be difficult once a nonprofit adopts a shared administrative arrangement.
- Both board and staff members may be further removed from financial information and controls.

benefits

- Improved organizational efficiency.
- Partners can concentrate on developing programs and program staff rather than administrative functions.
- Potential for other synergy due to increased communication between partners.

Joint Administrative Office: PATH Partners

Los Angeles' People Assisting the Homeless (PATH) just keeps innovating, first developing a single-site service center for 20 social service providers, and then extending its administrative capacity to others as part of PATH Partners. Gramercy Housing Group, Achieve Glendale, and PATH Ventures work under the PATH banner toward common housing support goals. However, perhaps the greatest benefit to the collaboration is the administrative support provided by PATH Partners, including support and oversight in executive management, finances, development, communications, public relations, and human resources.

The arrangement is simple: partner organizations pay a fee ranging from 5 to 12.5 percent of their annual budgets in return for administrative support. The partners collectively save costs through this centralized arrangement. Additionally, “greater coordination is achieved through standardized processes and protocols” for administrative tasks. Partner organizations retain their own corporation and boards. In the case of PATH Partners, participating organizations gain yet another benefit: senior level participation on a collective management committee geared toward increased communication and coordination of services. Although joint programming is not a current feature of PATH Partners, the model provides ample opportunity for it.

Model 8: Confederation

One well-known model of confederation is the United States, with individual states operating separately from, yet integrally part of, a federal whole. The umbrella organization exists because of the constituent parts, to which it provides services, coordination, and other support.

Among disparate similar entities, confederations can build coordination out of chaos and fragmentation. Cases differ in terms of how much control rests with the umbrella organization. In some cases, the umbrella organization tightly controls resources and information. In other cases, the umbrella organization clearly answers to its members.

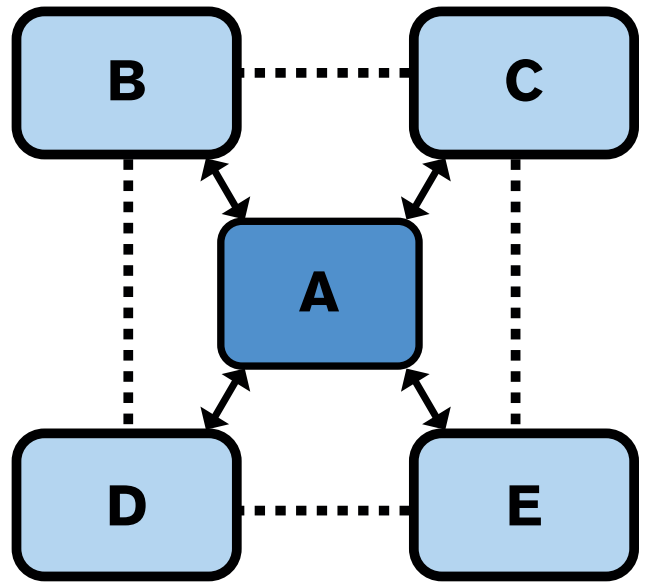

conditions

- Multiple, similar organizations providing services to different communities.
- Willingness to both defer to and draw from a centralized umbrella organization.
- The need to coordinate and network services across regions.

challenges

- Balancing authority of an umbrella organization with the autonomy of affiliates.
- Ensuring that affiliate interests are sufficiently represented in the strategic direction of the umbrella organization.
- Communications and networking needs can be complex.

benefits

- Increased exposure with branding beyond the local community.
- Support, services, and stability from the umbrella organization.
- Coordination of activities across regional boundaries, potentially including the sharing of resources.

A Confederation of Workplace Giving Campaigns: Earth Share

In the early years of the environmental movement, states and regions established federations to support the visibility and fundraising efforts of environmental causes. Earth Share was originally founded to serve the collective fundraising needs of a consortium of national organizations, but even then was at odds with state and regional federated fundraising drives. In 2001, Earth Share reorganized with an affiliate structure that included 15 state or regional federations. For Earth Share, collaboration replaced competition and territoriality. For the affiliates, Earth Share was a stabilizing parent that provides “capacity building resources, technology upgrades, technical assistance, a shared contact management database, a centralized pledge processing and distribution system, and better nonprofit management training.”

Earth Share affiliates are equal partners with the national organization, and affiliate representatives have 11 of 33 slots on the national board. In addition to branding and coordination efforts afforded by the confederation, affiliates have been able to concentrate more on local issues and conditions rather than on competition with national federated campaigns.



the **collaboration** prize

Presented by

THE LODESTAR FOUNDATION 

in partnership with

AIM  **ALLIANCE**
ARIZONA STATE UNIVERSITY · INDIANA UNIVERSITY · GRAND VALLEY STATE UNIVERSITY

Publication created by

ASU **Lodestar Center**
for Philanthropy & Nonprofit Innovation
ARIZONA STATE UNIVERSITY